

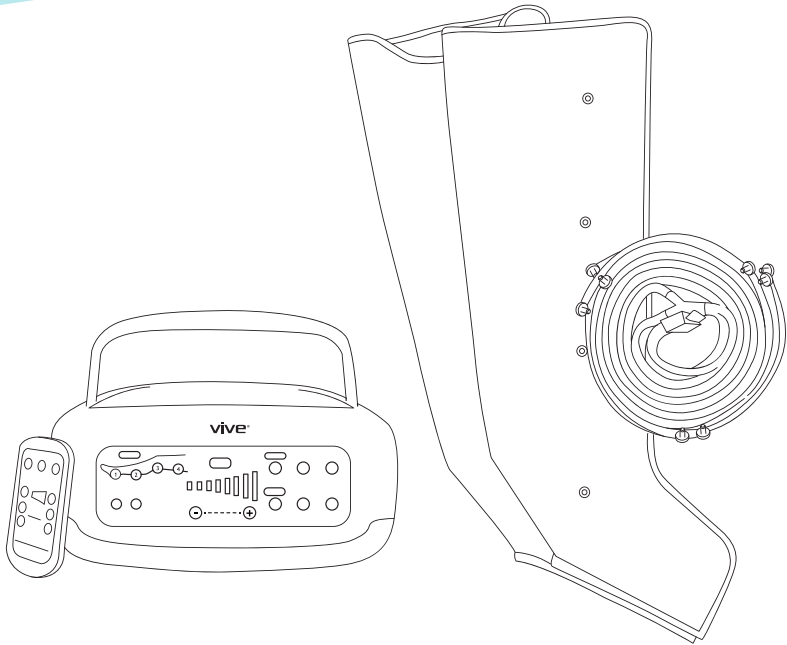

# LEG COMPRESSION MACHINE

USER MANUAL



[artikmed.com](http://artikmed.com)

## PUMP SPECIFICATIONS

Power Consumption: 30 W

Input Voltage: 110 V

Pressure Range: 30-250mmhg

## QUICK START GUIDE

**Note:** For first time use, open filter cover and remove the screw.

1. Connect power cord to a power outlet
2. Securely connect air hose to the pump
3. Connect the air hose to the leg cuff

**Note:** Be sure to match the connectors with the correct color

3. Insert leg into the leg cuff
4. Press the power button
5. Select the desired pressure using the pressure control
6. Set the inflate and deflate times as desired

## MESSAGE MODES: THREE SET MODES

### A:

In this mode, only a single chamber inflated at a time. Starting from the toes and working up to the thigh. Then the cycle repeats. Ideal for massage.



## B:

In this mode, the toe chamber stays inflated. It gradually adds a chamber until all four are filled with air. Then the cycle repeats. Ideal for lymphatic edema treatment.



## C:

In this mode, every other chamber is inflated. This is great for massage and post workout recovery.



## CLEANING AND MAINTENANCE

- Turn off pump before cleaning.
- Wipe with a damp cloth.

## WARNINGS

- Do not unzip the garment when the unit is on.
- Always turn the power off before unzipping the cuff.
- Do not get the pump wet.
- Make sure the pump is on a flat surface.

## ACTIVATE YOUR GUARANTEE



You are protected by Artik Med's industry leading guarantees and customer service:

If you did not purchase through [vivehealth.com](https://vivehealth.com), please register at <https://artikmed.com/> to validate your guarantee.

**Product Code: RHB1019**

 <https://artikmed.com/>

 1-800-487-3808  
Monday - Friday 9am - 5pm EST